

VA 521 - Compact Inline flow meter for compressed air and other gas types

No inlet sections necessary – integrated flow straightener - Sensor unit can be removed

The newly developed VA 521 combines modern digital interfaces for connection to an energy monitoring system with a small, compact design. The VA 521 is always used when many machines (compressed air consumers) are to be integrated into an energy monitoring network.



Display values can be rotated by 180° in the display, e. g. when installing overhead

Display shows 2 values at the same time:

- Actual Flow in m³/h, l/min,...
- Total consumption (meter reading) in m³, l, kg
- Temperature measurement

Screw thread:

Easy installation in existing piping through integrated measuring block (suitable for 1/2", 3/4", 1", 1 1/4", 1 1/2" or 2" lines)

The advantages at a glance:

- Compact, small design - for use in machines, behind maintenance unit at the end user
- All interfaces are programmable via the display
- Modbus RTU output
- 4...20mA analog output for actual flow
- Pulse output total flow (counter reading), galvanically isolated. Optionally M-Bus, Ethernet-Interface, or PoE

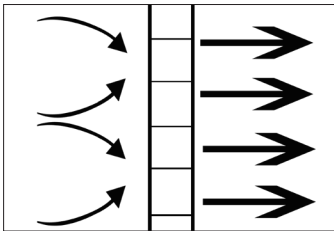

Integrated flow straightener - no inlet sections necessary



With keystroke:

- Reset counter
- Select units
- Parameterize interface



The sensor can be removed from the measuring block and cleaned

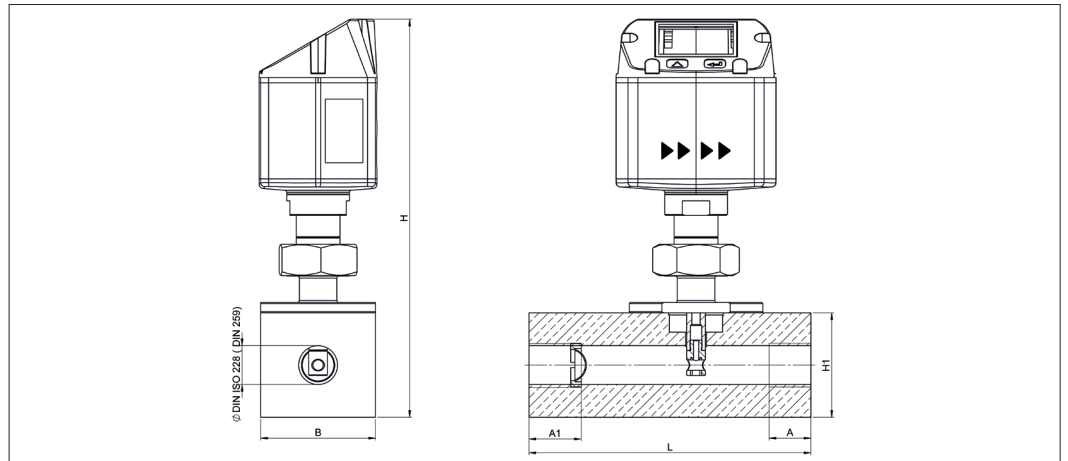

Measuring ranges flow VA 521 (Max version 185 m/s) for compressed air (ISO 1217: 1000 mbar, 20 °C). Measuring ranges for other gas types see pages x to x

Measuring section	Thread	Measuring range		L mm	B mm	H1 mm	H mm	A mm	A mm
		m³/h	cfm						
DN 15	G 1/2"	90 m³/h	50	135	55	50	109.65	25	20
DN 20	G 3/4"	170 m³/h	100	135	55	50	109.65	26	20
DN 25	G 1"	290 m³/h	170	135	55	50	109.65	33	25
DN 32	G 1 1/4"	530 m³/h	310	135	80	80	215.45	35	25
DN 40	G 1 1/2"	730 m³/h	430	135	80	80	215.45	36	25
DN 50	G 2"	1195 m³/h	700	135	80	80	215.45	44	30

Example order code VA 521:

0696 0521_A1_B1_C1_D1_E1_F1_G1_H1_I1_J1_K1_L1_M1_R1

Measuring block	
A2	1/2"
A3	3/4"
A4	1"
A5	1 1/4"
A6	1 1/2"
A7	2"

Threaded version	
B1	G female thread
B2	NPT female thread

Material	
C1	Aluminium
C2	Stainless steel 316L

Calibration	
D1	No real gas adjustment - gas type setting by gas constant
D2	Real gas calibration in the gas type selected below

Gas type	
E1	Compressed air
E2	Nitrogen (N2)
E3	Argon (Ar)
E4	Carbon dioxide (CO2)
E5	Oxygen (O2)
E6	Nitrous oxide (N2O)
E90	Further gas / please indicate gas type (on request)
E91	Gas mixture / please indicate mixture ratio (on request)

Measuring range (see table)	
F1	Low Speed version (50 m/s)
F2	Standard version (92,7 m/s)
F3	Max version (185 m/s)
F4	High Speed version (224 m/s)

Reference standard	
G1	20 °C, 1000 mbar
G2	0 °C, 1013,25 mbar
G3	15 °C, 981 mbar
G4	15 °C, 1013,25 mbar

Option display	
H1	with integrated display
H2	without display

Option pressure measurement	
I1	without pressure sensor

Option signal / bus connection	
J1	1x 4...20 mA analog output not galvanically isolated, pulse output, RS 485 (Modbus RTU)
J2	Ethernet-Interface (Modbus/TCP), 1 x 4...20mA analog output not galvanically isolated, RS 485 (Modbus RTU)
J3	Ethernet-Interface Power over Ethernet (Modbus TCP), 1 x 4...20mA analog output not galvanically. isolated, RS 485 (Modbus RTU)
J4	M-Bus, 1 x 4...20mA analog output not galvanically isolated, RS 485 (Modbus RTU)

Flow straightener	
K1	with integrated flow straightener, no additional inlet pipe necessary (with measuring block 1/2" to 2")

Accuracy class	
L1	± 1,5% of m. v. ± 0,3% of f. s.
L2	± 1% of m. v. ± 0,3% of f. s.

Maximum pressure	
M1	16 bar
M2	40 bar

Surface condition	
N1	Standard design
N2	Special cleaning oil and grease-free (e. g., for oxygen use, etc.)
N3	Silicon free including special cleaning oil and grease free

Special measuring range	
R1	Special measuring range (please specify when ordering)

Order-No. VA 521

DESCRIPTION	ORDER-NR.
Compact inline flow sensor	0696 0521 + order code A_...R_

Further accessories see page 82 bis 86

TECHNICAL DATA VA 521	
Parameters:	m ³ /h, l/min (1000 mbar, 20 °C) in case of compressed air resp. Nm ³ /h, NI/min (1013 mbar, 0°C) in case of gases
Units adjustable via keys at display:	m ³ /h, m ³ /min, l/min, l/s, ft ³ /min, cfm, m/s, kg/h, kg/min, g/s, lb/min, lb/h
Sensor:	Thermal mass flow sensor
Meas medium:	Air, gases
Gas types over CS Service Software or CS Datalogger adjustable:	Air, nitrogen, argon, CO2, oxygen
Measuring range:	See table
Accuracy: (f. M. = from the measured value) (f. E. = from end value)	± 1,5 % of m. v. ± 0,3 % of f. s. By request: ± 1 % of m. v. ± 0,3 % of f. s. or ± 6 % of m. v. ± 0,5 % of f. s.
Pressure measurement:	0...16 bar, accuracy: 1%
Operating temp.:	-30...80 °C
Operating pressure:	Up to 16 bar, optional 40 bar
Digital output:	RS 485 interface (Modbus RTU), (optional) M-Bus, Ethernet interface or PoE
Analog output:	4...20 mA for m ³ /h resp. l/min
Pulse output:	1 pulse per m ³ or per liter galvanically isolated. Pulse value adjustable on the display. Alternatively, the pulse output can be used as an alarm relay.
Power supply:	18...36 VDC, 5 W
Burden:	< 500 Ω
Housing:	Polycarbonate (IP 65)
Meas. section:	Aluminium, 316L
Mounting thread meas. section:	G 1/2" to G 2" (BSP British standard piping) resp. 1/2" to 2" NPT-thread
Mounting position:	Any